

ELECTRO-HYDRAULIC DOCK-LEVELLER mod. KRB (A)

KRB dock-levellers are composed by a steel frame, made with welded profiles, and the upper plate and the lip by an anti skid steel sheet.

Reinforcing welded tubes under plate with section mm. 150 x 30 x 3, placed every 30 mm.
Thickness of upper plate mm. 6 + mm. 2 of anti skid ribs

Thickness of rotative flap: mm. 14 + bottom reinforcing welded plate, mm 120 x thickness 10
Diameter of hinges: internal mm. 35 – external mm. 55

Hinge between main plate and lip is continuous on the full width of the ramp.

Hydraulic movement of lifting and opening of the lip is by means of single effect chromed pistons, whose electric command is under the dock-leveller.

Lifting cylinder diam. mm. 50 (core)

Lip rotation cylinder diam. mm. 40 (core)

It is possible to stop and secure maintenance operations by blocking the dock leveller using a special galvanized rod.

Security block: in case of accidental moving of the truck, the dock leveller will be blocked with a short stroke (according to the applied weight).

Every dock-leveller is equipped with lateral security galvanized plates for feet protection.

Once the edge is positioned on the loading part of the truck, this edge follows movements of it during loading operations, with a lateral torsion tolerance of 100 mm.

Every dock-leveller is coloured by blue painting RAL 5003

Electric commands in accordance to CEI IP 55 rules.

Power supply: 380 V 3phases

Control panel with up/down/stop, security stop, main power switch buttons; "dead man" operating system; low tension 24 V d.c. commands.

Electrical engine power Kw 0.55 - IP 55

Working pressure approx. 120 bar

Concentrated load on fork-lift allowed: kg. 6.000.max.

Uniformly distributed load: kg. 9.000. max.

All dock levellers are manufactured according to CE rules, and fully satisfy EN 1396 norms.

Side view

Length 2.500

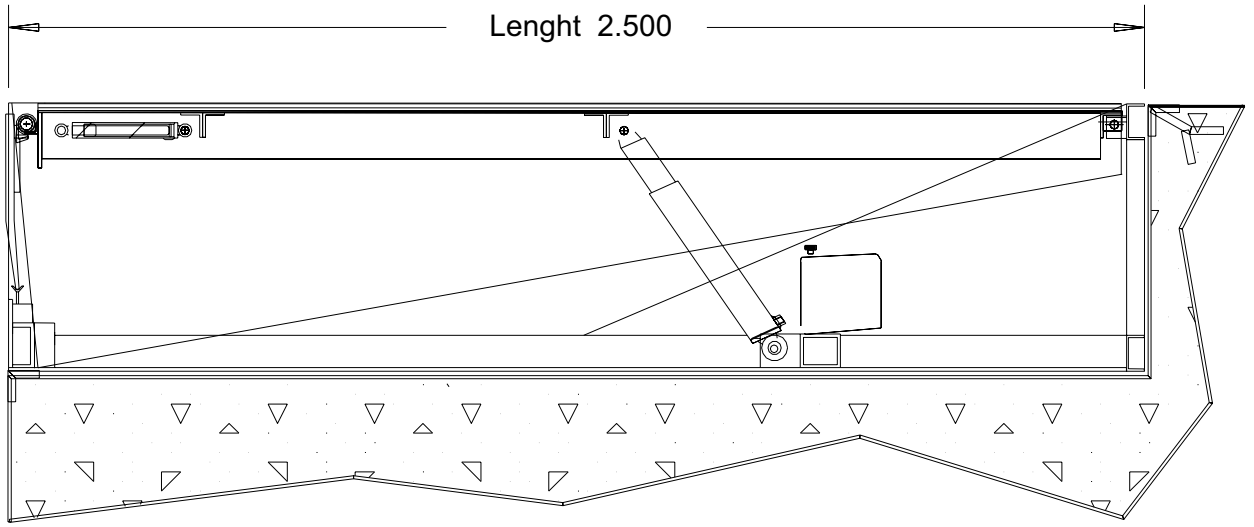

680

273

296

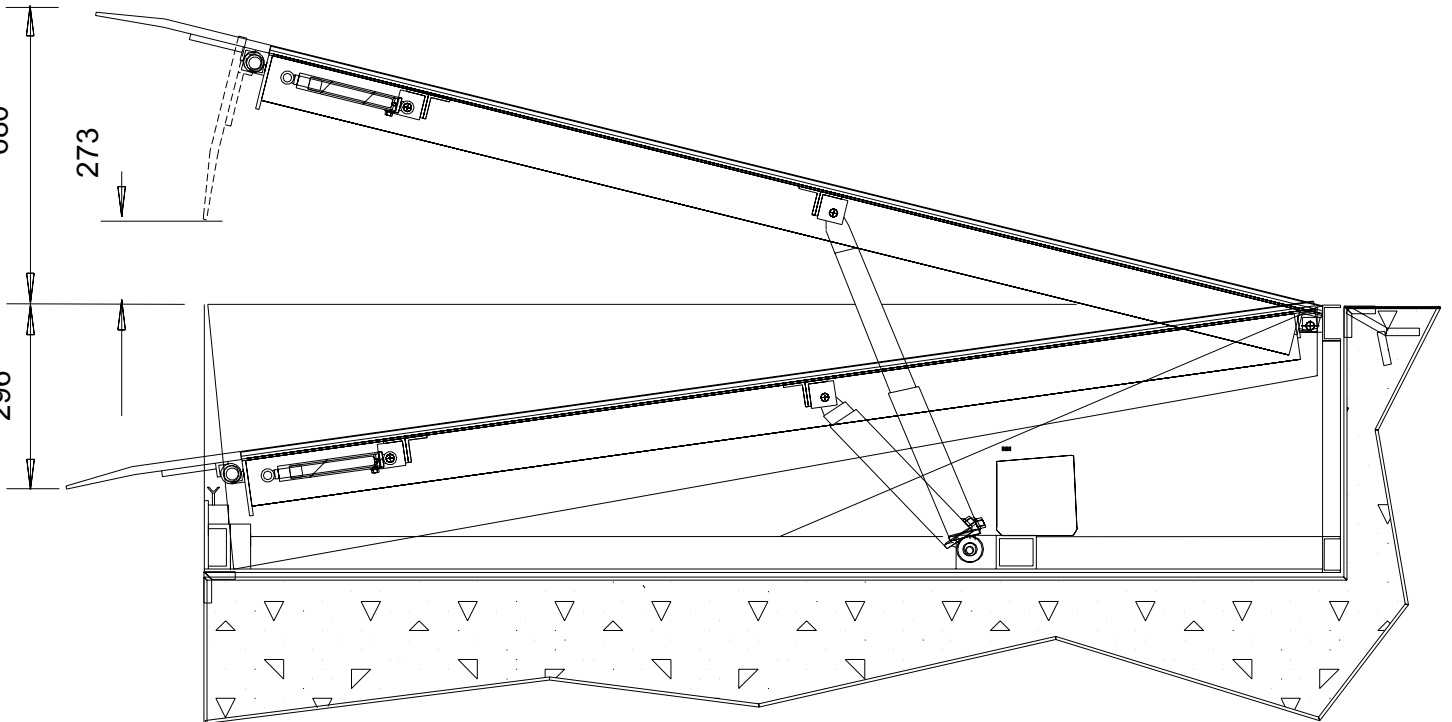

Width 2.000

H. 600

Lip 400

ASTECH

Front view

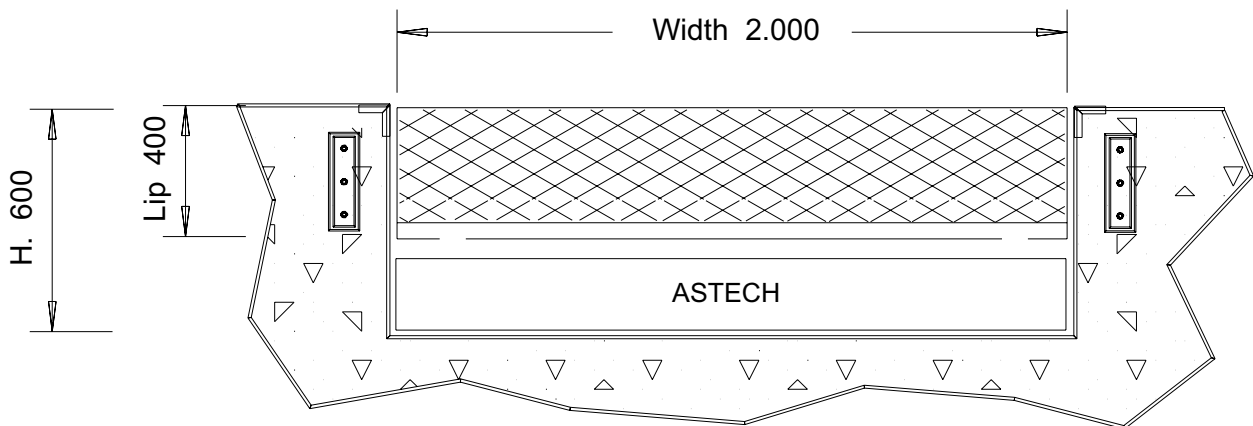

Dock Leveller with swinging lip Mod. KRB(A) - 2 c